



جامعة الجزائر- 3 -  
كلية العلوم السياسية والإعلام  
قسم علوم الإعلام والاتصال

# قضايا البيئة في الصحافة المكتوبة

دراسة تحليلية لجريدتي وقت الجزائر والشعب

مذكرة مقدمة لنيل شهادة الماجستير في علوم الإعلام والاتصال  
تخصص اتصال بيئي

إشراف الأستاذ:

أ.د: شوتري أحمد

إعداد الطالب:

نورالدين دهمار

السنة الجامعية: 2011 - 2012



[books4arab.com](http://books4arab.com)



---

)

((

**-41-**

)

((

**-85-**

## شكر وتقدير

\_\_\_\_\_

)

- 19 - ((

:

(( ))

.

:

o

.

.



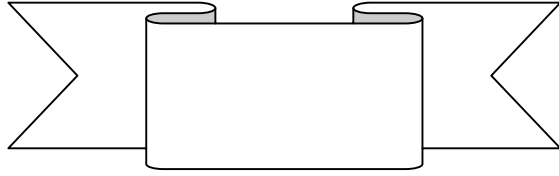

\_\_\_\_\_

-  
-  
-  
-  
-  
-  
-  
-  
-  
-  
-

:

:  
:  
:  
:

:

:  
:  
:

:

-

-

-

-

-

-

-

-





:

i

.

.

. . . .

.

f



. . . .

2003

1983

.

.

.

.

.

.

---

:

.

:

.

:

:

:

i

.

:

:

.

:

:

.

:

:

:

.



:

:

.

:

:

.

:

.

# الإطار المنهجي



:

.

.

.

.

1983

2003

---

.

.

.

.

.

:



:

"

:

"

-1

-2

-3

-4

-5

-6

-7

:

. (1)

:

"

•

"

. 87 1992 .

: (1)





.

•

.

•

.

.

•

•

.

:

:

:

:

•

.

•

.

•

•

.



•

( ) ( ) .( )

:

:

.

•

•

.

•

.

:

(1)

(2)

:

:

- 1

:

.

■

■

■

.



(1) : 1992 32 .  
(2) نجوى قصاب : ما المقصود بتحرير المرأة؟، بحث مقدم لندوة المرأة في المجتمع العربي، جامعة قار يونس، بنغازي، 1989، ص 33 .

:

(1)

- 2 :

(2)

- 3 :

- 4 :

- 5 :

(3)

:

- :

- :

(4)

- 6 :

(5)  
i

---

(1) حنان جنيد: المعالجة الصحفية للحرب الأنجلوأمريكية على العراق في صحيفتي الأهرام ونيويورك تايمز، المجلة المصرية لبحوث الاتصال، كلية الإعلام، جامعة القاهرة، العدد 19، أبريل جويلية 2003، ص 115 .  
(2) أحمد عاطف غيث: قاموس علم الاجتماع، الهيئة المصرية للكتاب، القاهرة، 1979، ص 160 .  
(3) ليلي عبد المجيد وآخرون: كيفية إعداد قضايا البيئة للنشر في الصحف، ندوة الإعلام وقضايا البيئة في مصر والعالم العربي، كلية الإعلام، جامعة القاهرة، أبريل 1992، ص 287 - 296 .  
(4) نفين أحمد غياشي: الإعلام وقضايا التنمية، دار الإيمان للطباعة، القاهرة، 2005، ص 162 .  
(5) خليل صابات: وسائل الاتصال نشأتها وتطورها، مكتبة الأنجلو المصرية، القاهرة، 1985، ص 182 .

:

(1)

(2)

:

:

:

"

- 1

"(3)"

1989

1986

01

:

%6.21

(1) دوقان عبيدات وآخرون : البحث العلمي، مفهومه، أدواته، أساليبه، دار أسامة للنشر والتوزيع ، الرياض، 1999، ص 92 .  
(2) حلمي محمد فودة، عبد الرحمن صالح عبدا لله : المرشد في كتابة الأبحاث، دار الشروق، جدة، 1992، ص 240 .  
(3) محمود عبد الرحمان : معالجة قضية حماية البيئة الريفية في الصحافة الزراعية، رسالة دكتوراة غير منشورة، معهد البحوث والدراسات البيئية، جامعة عين شمس، 1993 .

.	-		
.	-		
	- 2		
		(1)	
)			
(		(	
		1986	1982
:			
			-
%81.24			
%1		%17.7	
1986		1985	
.			-
.			-
.			-

(1) حلمي عزيز حنا: مشكلة تجريف الأراضي الزراعية في الصحافة المصرية، رسالة ماجستير غير منشورة، معهد البحوث والدراسات البيئية، جامعة عين شمس، 1989 .

"

- 3

(1)"

:

)

(

1999

400

:

-

-

-

---

(1) رحاب إبراهيم سليمان عيسى: الصحافة المصرية وترتيب أولويات الصفوة اتجاه قضايا البيئة في إطار مفهوم التنمية المتواصلة في مصر، رسالة ماجستير غير منشورة، كلية الإعلام، جامعة القاهرة، 1999 .

- 4

«(1)»

»

:

)

09

2005

2004

228

:

192

35

---

(1) لبنى عبد العزيز الجابري: معالجة القضايا البيئية في القنوات العربية، رسالة ماجستير غير منشورة، كلية الإعلام، جامعة القاهرة، 2007.

			-
			-
	"		-5
	"(1)"		
	:		
	.		
	:		
:			
	:		-
			✓
			✓
			✓
			✓
	:		-
			✓
			✓
			✓

(1) نهلة مظهر أبو رشيد: برامج التوعية البيئية في التلفزيون المصري والسوري دراسة مقارنة، رسالة ماجستير غير منشورة، كلية الإعلام، جامعة القاهرة، 1999 .



---

1999

:

-

%41

%39

"

- 6

"(1)

:

:

✓

:

✓

✓

✓

✓

---

(1) رضوان سلامن: الإعلام والبيئة، دراسة استطلاعية لعينة من الثانويين والجامعيين مدينة عنابة نموذجاً، رسالة ماجستير غير منشورة، قسم علوم الإعلام والاتصال، جامعة الجزائر، 2006.

---

300

2006 2005

:			
% 65,3			-
	.	% 44,6	
.% 14.7	% 78		-
.			-
			-
			.
		:	
		:	
"(1)		"	-1

---

(1) سامي طابع: دور وسائل الإعلام في نشر الوعي البيئي، ندوة الإعلام وقضايا البيئة في مصر والعالم العربي، مطبعة كلية الإعلام، جامعة القاهرة، أبريل 1992 .



"(1)

"

- 2

1991

1990

:

-

-

-

"(2)

"

- 3

.1987

:

-

-

---

(1) نجوى كامل: الصحافة العلمية وقضايا البيئة دراسة تطبيقية على صفحة الأهرام، بحث منشور في كتاب ندوة الإعلام وقضايا البيئة في مصر والعالم العربي، مطبعة كلية الإعلام، جامعة القاهرة، أبريل 1992 .  
(2) سهام نصار: دور الصحافة في التوعية بمشكلات البيئة في مصر، مجلة كلية الآداب، جامعة سوهاج، العدد 12 ، 1992 .

			-
"(1)"		"	- 4
			)
.1996		(	
	:		
%0.35			-
			-
			-
% 85.5			-
. % 02,8		%11.7	
"(2)"		"	- 5

(1) أديب خضور: سلسلة بحوث إعلامية، المكتبة الإعلامية، دمشق، 1999، ص 75 .  
(2) عاطف عدلي العبد: الإعلام العماني وقضايا البيئة، دراسة استطلاعية، دار الفكر العربي، القاهرة، 1992 .

---

:

-

.

-

.

"

- 6

"(1)

( )

180

:

-

---

(1) عادل عبد الغفار: رؤية مستقبلية لتفعيل دور وسائل الإعلام الجماهيري في تنمية الوعي البيئي، المجلة المصرية لبحوث الاتصال، كلية الإعلام، جامعة القاهرة، العدد 27، جويلية- سبتمبر 2007 .

---

.

-

.

-

.

-

.

:

:

-

.

-

.

---

-

.

-

.

:

-

:

-1

.

-2

.

-3

.

-4

.

:

(1)

---

(1) سمير حسن: تطبيقات في مناهج البحث العلمي، عالم الكتب، القاهرة، 1991 ، ص 87 .



.

:

(1)

.

:

(2)

.

:

(3)

.

01 2011 31 2011 .2011

:

:

---

(1) شحاتة سليمان محمد، إيمان نور الدين الشامي: محاضرات في حلقة البحث، حورس للطباعة والنشر، القاهرة، 2003، ص 256 .  
(2) رشيد زرواتي: مناهج وأدوات البحث العلمي في العلوم الاجتماعية، دار الهدى للطباعة والنشر والتوزيع، عين مليلة، 2007، ص 135 .  
(3) عاطف عدلي العبد، زكريا أحد عزمي: الأسلوب الإحصائي واستخدامه في الرأي العام والإعلام، دار الفكر العربي، القاهرة، 2002، ص 208 .



---

- :

- :

■ :

■

· :

(1)

147

25

:

---

(1) وجيهه محجوب: أصول البحث العلمي، دار المناهج للنشر والتوزيع، 2005، ص 149 .

:

:(01)

2011/06/09	<b>708</b>	2011/04/07	<b>655</b>	2011/02/03	<b>601</b>
2011/06/16	<b>714</b>	2011/04/14	<b>661</b>	2011/02/10	<b>607</b>
2011/06/23	<b>720</b>	2011/04/21	<b>667</b>	2011/02/17	<b>613</b>
2011/06/30	<b>726</b>	2011/04/28	<b>673</b>	2011/02/24	<b>619</b>
2011/07/07	<b>731</b>	2011/05/05	<b>678</b>	2011/03/03	<b>625</b>
2011/07/14	<b>737</b>	2011/05/12	<b>684</b>	2011/03/10	<b>631</b>
2011/07/21	<b>743</b>	2011/05/19	<b>690</b>	2011/03/17	<b>637</b>
2011/07/28	<b>749</b>	2011/05/26	<b>696</b>	2011/03/24	<b>643</b>
/	/	2011/06/02	<b>702</b>	2011/03/31	<b>649</b>

:(02)

2011/06/06	<b>15511</b>	2011/04/02	15456	2011/02/02	<b>15407</b>
2011/06/14	<b>15518</b>	2011/04/10	15463	2011/02/10	<b>15414</b>
2011/06/22	<b>15525</b>	2011/04/18	15470	2011/02/12	<b>15415</b>
2011/06/30	<b>15532</b>	2011/04/26	15477	2011/02/20	<b>15421</b>
2011/07/02	<b>15533</b>	2011/05/04	15483	2011/03/07	<b>15434</b>
2011/07/10	<b>15539</b>	2011/05/12	15490	2011/03/15	<b>15441</b>
2011/07/18	<b>15546</b>	2011/05/21	15497	2011/03/23	<b>15448</b>
2011/07/26	<b>15553</b>	2011/05/29	15504	2011/03/31	<b>15455</b>

:

. 2011

: - 1

:

(1)

(1) عاطف عدلي العبد: استطلاعات وبحوث الإعلام والرأي العام تصميمها تنفيذها، دار الفكر العربي، القاهرة، 2009، ص 47 .



.

:

.

.

:

-

:

-

.

:

-

.

:

-

.

(1)

"

"

:

"

"

(2)

.

---

(1) سمير محمد حسن: تحليل المضمون، عالم الكتب، القاهرة، 1983، ص 88 .  
(2) رشدي طعيمة: تحليل المحتوى في العلوم الإنسانية، مفهومه، أسسه، إستخداماته، دار الفكر العربي، القاهرة، 1987، ص 63 .



: -1

:  
: -1-1

:  
: -1-1-1

)  
.(  
: -2-1-1

.  
: -3-1-1

.  
: -4-1-1



: - 5-1-1

: - 6-1-1

: - 7-1-1

: - 8-1-1

: - 9-1-1

:  
:  
- 10-1-1

: - 11-1-1

: - 12-1-1



: -13-1-1

: -2-1

:

: -1-2-1

: -2-2-1

: -3-2-1

: -3-1

:

: -1-3-1

.

: -2-3-1

(1)

: -3-3-1

.





: -4-3-1  
.  
: -5-3-1  
.  
: -4-1  
:  
: -1-4-1  
.  
: -2-4-1  
.  
: -3-4-1  
.  
: -5-1  
.  
: -6-1  
:  
.  
: -7-1  
:



	:	- 2
	:	- 1-2
	:	
	:	- 1-1-2
(1).		
	:	- 2-1-2
(2).		
	:	- 3-1-2
(4).		
	:	- 4-1-2
(5).		
	:	5-1-2
(6).		
	:	- 2-2
:		

(1) محمد لعقاب: الصحفي الناجح، دار هومة للطباعة والنشر والتوزيع، الجزائر، 2004، ص 54 .  
(2) أشرف صالح، محمود علم الدين: مشروع إصدار جريدة أو مجلة، مركز جامعة القاهرة للتعليم المفتوح، القاهرة، 2003، ص 105 .  
(4) نصر الدين لعياضي: اقترايات نظرية من الأنواع الصحفية، ديوان المطبوعات الجامعية، الجزائر، 1990، ص 58 .  
(5) فاروق أبو زيد: فن الكتابة الصحفية، عالم الكتب، القاهرة، 1990، ..  
(6) عبد العالي رزاق: المقال والمقال، الطبعة الأولى، دار هومة للطباعة والنشر والتوزيع، الجزائر، 2006، ص 77 .



: - 1-2-2

.

: - 2-2-2

.

: - 3-2-2

.

: - 4-2-2

.

: - 3-2

.

: - 4-2

.

: - 5-2

.

: - 6-2

:

: - 1-6-2

: - 1-1-6-2

.



: - 2-1-6-2

.

: - 3-1-6-2

.

: - 2-6-2

: - 1-2-6-2

.

: - 2-2-6-2

.

: - 3-2-6-2

.

: - 4-2-6-2

.

:

.

.

(1)

(2)

Test Retest

(3)

-1

-2

% 25

(1) محمد عبد الحميد : البحث العلمي في الدراسات الإعلامية، عالم الكتب، القاهرة، 1989، ص 489 .

(2) أسماء الأساتذة المحكمين:

Ü 3

- 
- 
- 

(3) محمد الوفائي: مناهج البحث في الدراسات الاجتماعية والإعلامية، القاهرة، مكتبة الأنجلو المصرية، القاهرة، 1989، ص 156 .



. % 97

:

:

■

.

■

.

■

.

الفصل الأول

قضايا ومشكلات البيئة



:

.

1972

.

.

.

---

:

ECOLOGY

.

i

.

.

:

.

:

-

(1)

:

(2)

:

:

(3)

OIKOS

ECOLOGY

OIKOS :

LOGOS

---

. 39 1968 1 1 : (1)  
. 68 . . : (2)  
. 08 1999 . : (3)



(1)

i (Environment) :

i<sup>(2)</sup>

i1972

:

Environment "ensembles des éléments naturels ou artificiels qui conditionnent la vie de l'homme."<sup>(3)</sup>

(4)

i(Environment) :

(5)

:

-

:

---

. 28 1999

: (1)

. 104 1999

: (2)

<sup>(3)</sup>prieur Michel:droit de le Environnement,4 éd dolloz, 2001, p02 .

<sup>(4)</sup>le petit robert :1,pares, 1991, p 664.

<sup>(5)</sup>Langman distiounary of contumpary English :éd 1984, p 367.



---

<sup>(1)</sup>J. Seneca M.K. Jaussig : Environmental Economics , New jersey, Prentice-Hall, 1984, p3-4 .

. 17 2002 : (2)

. 13 2002 : (3)

. 27 2009 : (4)

. 09 2009 : (4)

. 10 2003 ;419 : (5)



:

(1)

.

:

:

:

-

.

:

-

.

:

-

.

:





:  
 : -1  
 : (1)

· ...

(2)

(3)

(4)

: -2

· 25 j 24 2006  
i2007

· 29 2008

---

: (1)  
 : (2)  
 . 23 (3)  
 : (4)  
 . 79

(1)

: Rau weoten

: -

: -

(2)

: -

:

( )

(3)

:

. 33 2007

: (1)

. 81 : (2)

<sup>(3)</sup>John Rau and David Wooter :Environmental impact analysis Hand Book- univ of California , Meg Raw Hill company ,1980, P 24.



(1)

(2)

(3)

:

:

-

.

:

-

.

:

-

(4)

:

:

i<sup>(5)</sup>

i<sup>(6)</sup>



	. 37	2002	:	(1)	
		. 11	2005	:	(2)
	. 200	1994	:	(3)	
. 25j 22			:	(4)	
	. 17	2003	:	(5)	
	. 36	1987	:	(6)	

i<sup>(1)</sup>

i<sup>(2)</sup>

(3)

(4)

.

.

:

:

:

- **1**

:

:

-

.

:

-

.

:

-

.

---

. 06 1985  
. 18 2009  
. 15 2006  
. 29 2008

:

(1)

:

(2)

:

(3)

:

(4)



: -2

.(1)

. :

: -

:

: -1

.

: -2

.

: -

:

. : -1

: -2

. ..

: -3

(2)

.

. :

:

: -

.

. 20 1999

. 28 j 27

2009

: (1)

: (2)





: -

.

: -

.

: -

(1)

.

:

(2)

: (3)

.

- 
- 
- 
- 

.

.

.

. 22 j21 1999 .

. 48 1999

: (1)

: (2)

. 25 : (3)



. :  
 . :

.

(1)

1972

.

1992

27

i21

i1992/05/09

.<sup>(2)</sup>1992/06/05

1997

. 45 1989 03

. 118 i 117

: (1)  
: (2)

(1)

(2)

:

.

.

.

(3)

.

■

■

■

■

:

1986

"

"

1991

(4) 1992

.

: (1)

. 40 2007

. 80 1992 110

: (2)

. 52 : (3)

. 210 : (4)



(1)

:

300 1869

i<sup>(2)</sup>

:

:

-1

-

.1975

1972

1992

-

.

:

-2

1975

-

.

1987

-

.

. 210

:

(1)

. 179 1997

:

(2)



-

1989

: -3

: -4

1980 -

: -5

.1973 -

-

: -6

(1)

:

122 i66 i55 i54 i34 i<sup>(2)</sup>

...

. 207i 206 : (1)

. 78 2000 : (2)



i1972

1974

. (1)

2001

. (2)

. ...

i1983/02/05

03/83

10/03

i03/83

2003

19

.

. 219 2008

: (1)

: (2)

. 12 2007



.(1)

.

.

:

.

:

.

.

:

( )

.

.

:

.

.

:

.

.

:

.



---

. :

.

:

(1)

970

2001 2001

.

:

-

.

. 96 2003

---

: (1)



---

(1)

72

(2) 14818

:

:2010 2001

:2005

2005

24.000

10.500

: 2001

2001 12

19Ü 01

---

<sup>(1)</sup>Mission Economique de l'Ambassade de France en Algérie: Fiche de synthèse sur le marché de l'environnement en Algérie, MINEFI-DGPTE, version n° 1 du 14 mars 2004, page 1.

<sup>(2)</sup>Ministère de L'aménagement du Territoire et de l'environnement: Rapport sur l'état et l'avenir l'environnement, Alger, 2005, P 205.



2004 19 09Ü03 ■

2004 14 09 Ü04 ■

2004 25 20Ü04 ■

: -

(1)

■

■

●

●

●

●

●

●

:

2.381.741:

1200

6000:

2

.



: (1)

7

. 17 2008 8



(1)

.

.

.(2)

.

10

100

50

.

220

08

134

•

.

:

.

■

.

■

.

■



: (1)

. 39 2001

. 07 2008 8 i 7

: (2)

---

				(1)
	:			
.	26500	:		■
.	9800	:		■
.	9500	:		■
.	1148300	:		■
:				
	%40			
	% 11	% 13	i% 20	
		% 80	% 70	
i% 51				
		(2) %40		
				■
				■
				■
				■

---

(1) Ministère de L'aménagement du Territoire et de l'environnement, Rapport sur l'état et l'avenir de l'environnement, Op .Cit, p 208 .



■

.

■

%62

(1)

.

:

.



:

(1)

.

.

.

.

:

(1)

:

:

-

(2)

## Pollution

:

<sup>(3)</sup> Dégradation d'un milieu par l'introduction d'un polluant

. 143 2009

:

(1)

. 844 1980

:

(2)

<sup>(3)</sup> le petit rober :lpares ,1991 , p 77.

---

Contamination :  
pollution :

(1)

: -

:

:

(2)

: 1974

(3)

:

(4)

:

(5)

:

(6)

---

	. 174	:	(1)
	. 24	:	(2)
. 82	2001	:	(3)
	. 105	:	(4)
	. 21	:	(5)
	. 38	:	(6)



:

(1)

:

:

-

.

:

-

(2)

:

■

.

■

■

■

■

■

■

.

(3)

■

:



i2007

:

. 30

:

(1)

(2)

. 36 i35

. 40

:

(3)





(1)

: -

(2)

: -

(3)

: -

:

:

: -1

(4)

: -2

:

: -1



	. 38	:		(1)
. 48	1999	:		(2)
	. 38	:		(3)
		:	. 45	(4)



: -2

. : -3

. :  
: -1

. : -2

(1)

. :  
: -1

. : -2

. : -3

: -4

(2)

:



. 45 : (1)

. 39 j38 : (2)

---

: -1

%01            % 21            %78

(1) %0.33

.  
:

(2)  
.

:

(3)  
.

:

(4)  
.

:

: -

.

: -

.

: -

(5)  
.

---

.116            :

. 51            :

. 37            :

. 80            :

. 52            :



:

:

-

.

:

-

(1)

(2)

.

:

-

.

:

-

(3)

:

-

(4)



. 39	1999	. 61	:	(1)
			:	(2)
		. 43	i42	(3)
		. 226	:	(4)

:

•

:

■

■

■

■

■

■

■

-2

(1)

:

%94

%71

%06

(2)

%75

%0.1

(3)

:

(4)

:

(5)

. 127

:

(1)

. 56

2005

:

(2)

. 07

:

(3)

2007

:

(4)

. 132

. 63

:

(5)



:

•

.

.

•

.

•

.

•

(1)

•

:

(2)

:

- 3

i<sup>(3)</sup>

(4)

(5)

:

:

-



. 40 : (1)

. 31 2001 : (2)

. 08 1992 : (3)

. 134 : (4)

. 63 : (5)



(1)

·  
:  
-

(2)

:  
- 3

( )

90

( )

·  
:

0.1

(3)

---

	. 46	(1)
. 134	:	(2)
. 48	:	(3)



:

(1)

(2)

:

:

.

:

.

:

-

:

-

.

:

-

.

:

:

-

.

:

-

.



:

(1)

:

(2)





(1)

:

■

.

■

.

.

■

■

.

■

.

■

(2)

:

- 4

.

:

(3)

.



. 49

:

(1)

. 158

:

(2)

. 94 1996

:

(3)



.

:

.

:

.(1)

:

.

:

-

:

-

.

:

-

.(2)

.



:

(1)

. 22

1997

. 19

:

(2)



(1)

:

.

:

(2)

:

(3)

:

(4)

:

"

(5)

:

. 96

:

(1)

. 33

:

(2)

. 80 1999

:

(3)

. 121

:

(4)

1985 11 7

:

(5)

.49



: -

: -

(1)

: -

: -

(2) ...

100

3970

1977

1984

3475

1992

(3)

3562

. 15 2001

: (1)

. 65 164 : (2)

. 65 2005 : (3)



(1)  
200  
20  
12  
(2)  
03  
:

·  
:  
·  
:  
·

---

. 169 : (1)  
. 31 : (2)



(1)

:

(2)

(3)

:

(4)

.

(5)

:

:

- 1

.

:

:

(1)

. 211 2008

(2)

:

. 247

(3)

. 211

:

. 72

:

(4)

. 76

:

(5)

---

: -2

: -3

(1)

: -4

(2)

:

(3)

---

.75 : (1)

.202 : (2)

.151 2008 . : (3)



:

(1)

(2)

:

(3)

%01

353

5700

2500 600

(4)

1989

1990

(5)



. 48

:

(1)

. 127

:

(2)

. 148 2009

:

(3)

. 47 2006

:

(4)

. 94

:

(5)



---

141

34

. %21

%05

. (1)

. (2)

. (3)

. 33 j32 2007

---

. 160 :

(1)

:

(2)

. 24 :

(3)

---

:

:

1985

( )

09

(1) %50

(2)

i(0)

(O<sub>3</sub>)

(0)

(O<sub>2</sub>)

(O<sub>2</sub>)

(O<sub>3</sub>)

30

25

(3)

---

. 46 : (1)

. 59 : (2)

. 104 : (3)

---

16

1994

.<sup>(1)</sup>1987/09/16

.<sup>(2)</sup>

.<sup>(3)</sup>

---

. 220 1998

: <sup>(1)</sup>

. 32 : <sup>(2)</sup>

. 52 : <sup>(3)</sup>



:

(1)

:

(2)

:

(3)

:

:

-1

10

178

30 %

15

20 % i %50

.

:

6

: (1)

. 04 2004

: (2)

. 17 2005/07/06

: (3)

. 205 2000



•

.

•

.

•

.

.

(1)

:

-2

.

20

.



:

(1)

---

: - 3

(1)

%35  
%14

: - 4

: - 5

---

. 201 : (1)

---

: -6

(1)

200 100

(2)

. 03 2008 08 07

---

. 141 : (1)

: (2)



:

.

.

.

.

.



الفصل الثاني

الإعلام وقضايا البيئة



:

.

.

.

.

.



:

.

.

.

.

:

:

.

:

:

-

.

:

-



(1)

:

:

(2)

:

(3)

:

(4)

:

(5)

:

(6)

:

(7)



. 11	1996		:	(1)
		. 294	:	(2)
			. 257	(3)
. 54	2004		:	(4)
. 37	1998	-	154	(5)
		. 149	2008	(6)
				(7)
		. 09		(7)



:

(1)

.

:

:

-

:

.

•

.

•

.

•

.

•

•

.

•

.

•

.

:

-

:

-

.



. 33

1999

.

:

(1)



: -

.

: -

(1)

.

:

.

:

: -1

.



.56-54 : (1)

---

: -2

. : -3

(1)  
. : -4

. : -5

:

---

. 76-58-57

:

(1)



: -

- :
  - Green blogs ■
  - Enviroblogs ■
  - Araenvironment Montior ■

.

: -

.

: -

ONE WORLD

(1)

.







. :

:  
: -1

.  
: -2

.  
: -3

: -4

.  
: -5

(1)



:

.

:

.

•

•

.

•

•

.

•

.

•

.

•

.

•

.

•

.

(1)

.





. :

:

: :

-

●

.

●

.

●

.

●

.

●

.

●

.

●

.

:

-

.

●

.

●

.

●

●

.

(1)

●



. 70-69

:

(1)



· :  
 :  
 : -1

· :  
 : -2

· :  
 : -3

· :  
 : -4

(1)  
 :  
 : -5

(2)

(3)

. 98 2003

. 66 2007

---

: (1)  
 . 15 : (2)  
 : (3)

---

:

.

.

:

(1)

:

. 143 1992 110

---

:

(1)



:

.

(1)

:

.

•

•

(2)

.

.

•

:

. 263

:

(1)

:

(2)

. 134 1991



(1)

:

:

**- 1**

.

:

**- 2**

(2)

.

:

1986

:

:

-

.

:

-

(3)

.



. 263

:

(1)

. 144

:

(2)

. 265- 264

:

(3)



:

•

.

•

.

•

.

•

(1)

.

.

:

:

■

.

■

.

■

.

■

.

■

.

:

✓

.

✓

.







. ✓

✓

.

✓

.

✓

.

✓

(1)

:

:

: -1

.

: -2

:

: -



. 82 : (1)

---

:

-

:

:

-

(1)

:

-

:

-

:

-

:

-

:

---

. 145

:

(1)



. :

: (1)

: -1

:

•

.

•

.

•

(2)

: -2

.

: -3

:

■

.



. 145 : (1)

. 78 -77 : (2)



■

.

■

(1)

:

- 4

(2)

(3)

.

i01

:

(1)

. 34

2010

. 147

:

(2)

. 271

:

(3)



.

:

:

■

.

■

.

■

(1)

.

.

■

:

:

:

**- 1**

(2)

.



. 150 1999

. 147

:

(1)

:

(2)

---

:

-2

:

:

-

.

:

-

(1)

.

:

:

.

■

■

■

.

■

.

■

.

■

.

■

(2)

.

---

. 152 -151

:

(1)

. 50-49

:

(2)



:

:

.

.

.

.

.

.

.

.

(1)

.

:

■

■

■

■

■

■

■

■

■

.

:

.

:

.

(2)

.

■

●

●

. 111 2007

. 200 -199

:

:

(1)

(2)



---

:

"

"

.

.

.

.

.

.





:

:

■

.

■

. (1)

:

■

.

■

.

■

■

(2)

.

. 57-56

:

(1)

i1998

154

:

(2)

. 74



:

(1)

:

- 
- 
- 
- 

(2)

:

)

:

-

(

:

-

(3)

:

-

---

. 160	:		(1)
. 154	:		(2)
. 272	:		(3)



:

:

-

.

:

-

:

■

.

■

.

.

■

.

■

.

■

■

.

■

■

(1)





:

:

:

**-1**

.

:

**-2**

.

:

**-3**

.

:

**-4**

.

:

**-5**

.

:

**-6**

.

:

**-7**

(1)



. 235

:

(1)



:

- 8

.

:

- 9

.

:

:

-

.

:

-

(1)

:

-

.

:

.

:

:

-

.

.

---

. 235

:

(1)



: -

(1)

:

:

- 
- 
- 
- 
- 
- 
- 
- 
- 
- 

(2)



. 242-239 : (1)  
 . 23 : (2)

---

.

:

:

-

(1)

.

.

:

-

.

■

.

■

.

■

.

■

.

■

.

■

.

---

. 185 . . . .

:

(1)



:

-

.

■

■

.

■

(1)

.

:

-

.

:

-

:

■

.

■

.

■

.

■

.

■

.

:

-

:







: -1

.  
: -2

.  
: -3

.  
: -4

(1)  
.

---

:

.

.

.

# الإطار التطبيقي



:  
: 1

. TV

2009

(1)  
:  
- 2

1963

16

1972

1994

:

:1972 1962 - 1

28

10

(1) تاريخ التصفح الالكتروني: 2011/06/23 .02 H30 .WWW.wakteldjazair.com

---

15 :1977 1973 -2  
% 48.50 1976

. 1977  
1982 1978

24 :

. .....

.

:

: -1

(1)

: -2

---

: (1)

.131 2006

:

-I

:(03)

			/
<b>388</b>	<b>120</b>	<b>268</b>	
<b>% 100</b>	<b>%30.92</b>	<b>% 69.07</b>	

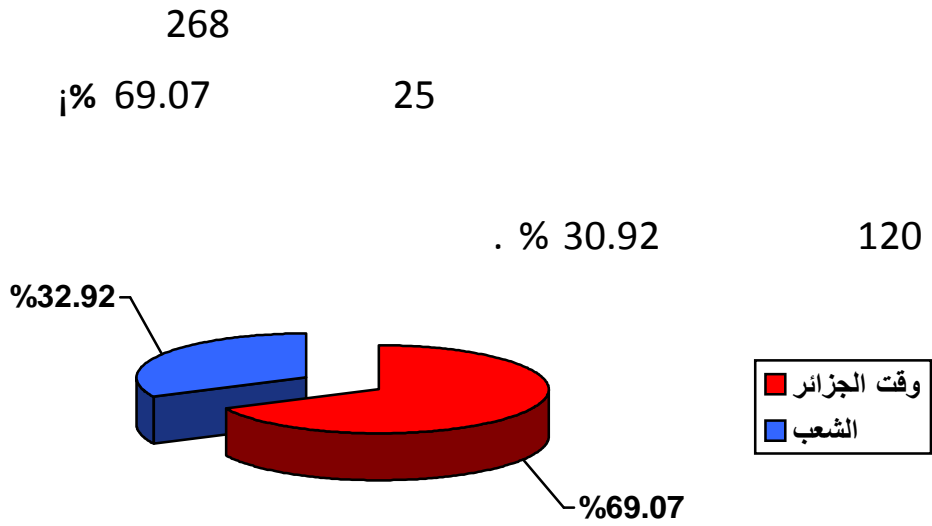

:(01)

: (04)

%3.86	15	% 3.33	04	% 4.10	11	
% 72.16	280	% 95	114	% 61.94	166	
% 20.87	81	Ü	Ü	% 30.22	81	
% 3,09	12	% 1.66	02	% 3.73	10	
% 100	388	% 100	120	% 100	268	

(1)

i% 72.16

i% 3,86

%20.87

. % 3.09

:

(1) عبد الفتاح عبد النبي: التناول الإعلامي لجرائم النخبة، دراسة النموذج المصري في الثمانينات، دار الفكر للثقافة والنشر، القاهرة، 1991، ص 20 .

-1 :

% 61.94  
% 30.22  
% 3.79  
% 4.10

-2 :

% 95  
% 1.66  
% 3.33

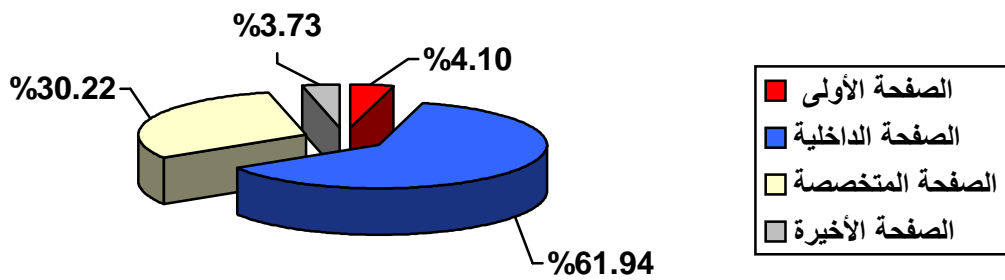

(02) :

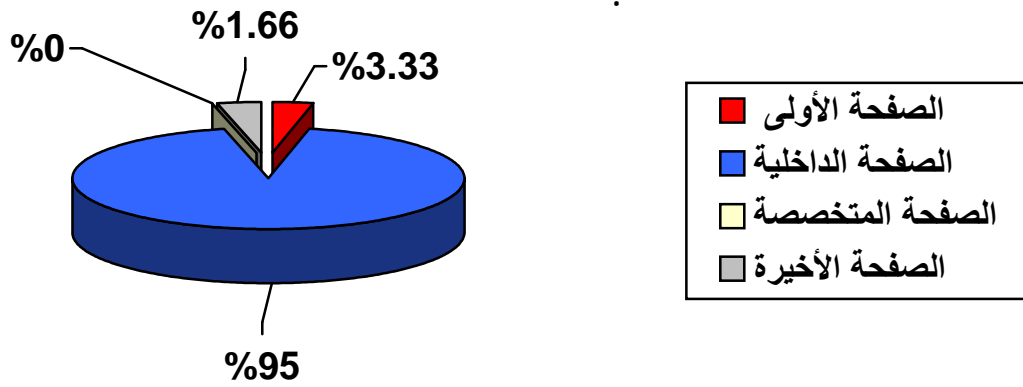

(03) :



: (05)

<b>% 54.89</b>	<b>213</b>	<b>% 60.83</b>	<b>73</b>	<b>%52.23</b>	<b>140</b>	
<b>% 45.10</b>	<b>175</b>	<b>% 39.16</b>	<b>47</b>	<b>% 47.76</b>	<b>128</b>	
<b>% 100</b>	<b>388</b>	<b>% 100</b>	<b>120</b>	<b>% 100</b>	<b>268</b>	

% 54.89

% 45.10

:

:

- 1

i % 52.23

. % 47.76

:

- 2

%60.83

. % 39.16

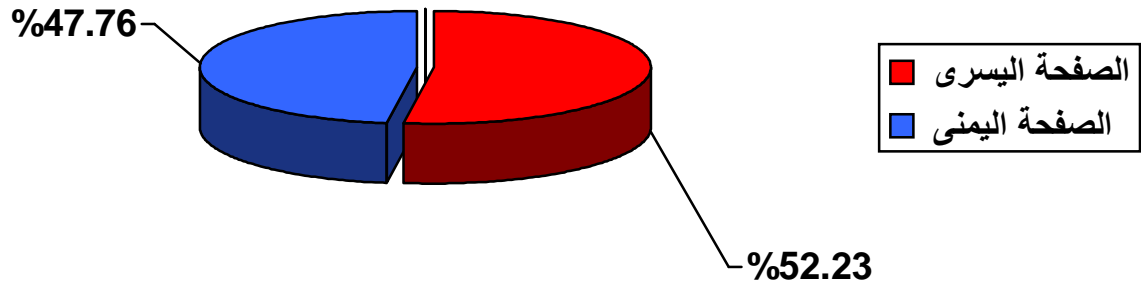

:(04)

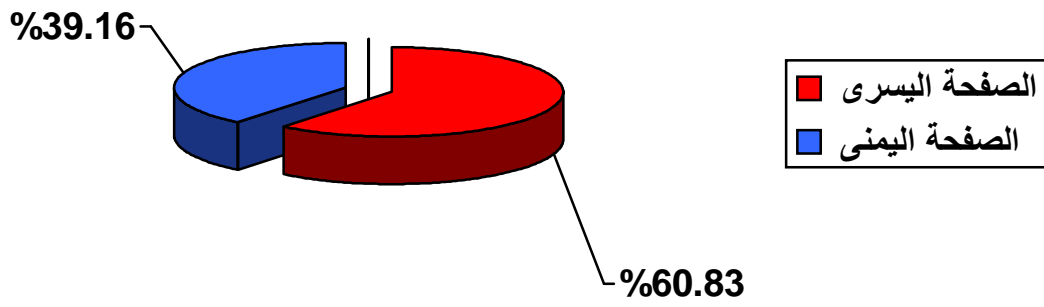

:(05)

---

:(06)

<b>% 33.76</b>	<b>131</b>	<b>% 29.16</b>	<b>35</b>	<b>% 35.82</b>	<b>96</b>	
<b>% 32.21</b>	<b>125</b>	<b>% 26.66</b>	<b>32</b>	<b>% 34.70</b>	<b>93</b>	
<b>% 34.02</b>	<b>132</b>	<b>% 44.16</b>	<b>53</b>	<b>% 29.47</b>	<b>79</b>	
<b>% 100</b>	<b>388</b>	<b>% 100</b>	<b>120</b>	<b>% 100</b>	<b>268</b>	

:

:

% 34.02

.% 32.2

% 33.76

:

%35.82

:

- 1

%34.70

% 29.47

:

- 2

% 44.15

% 29.16

. % 29.66

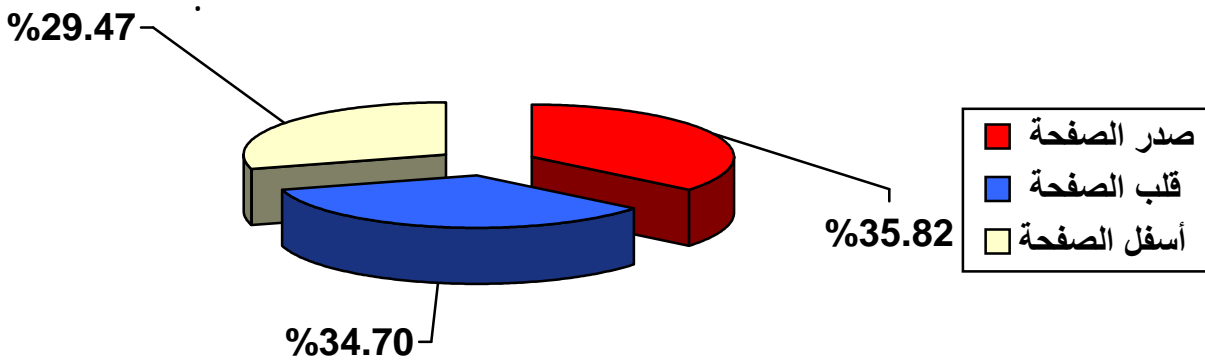

:(06)

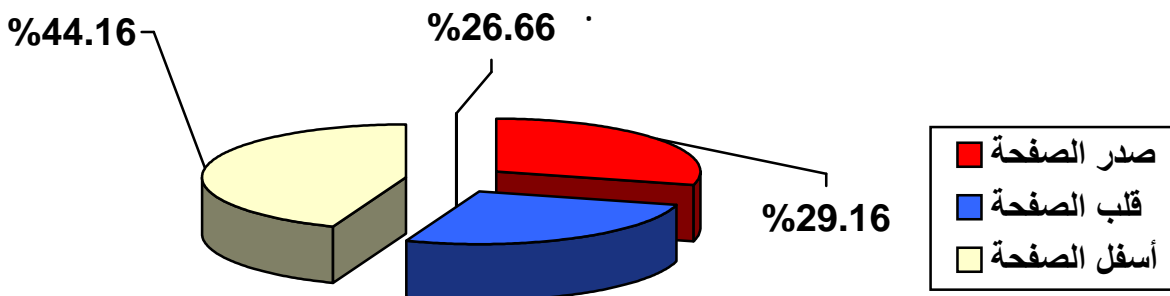

:(07)

---

:(07)

<b>% 13.35</b>	<b>13</b>	<b>% 4.16</b>	<b>05</b>	<b>% 2.98</b>	<b>08</b>	
<b>% 40.97</b>	<b>159</b>	<b>% 55</b>	<b>66</b>	<b>% 34.70</b>	<b>93</b>	
<b>% 55.67</b>	<b>216</b>	<b>% 40.83</b>	<b>49</b>	<b>% 62.31</b>	<b>167</b>	
<b>% 100</b>	<b>388</b>	<b>% 100</b>	<b>120</b>	<b>% 100</b>	<b>268</b>	

% 40.97

% 55.67

% 13.35

:

:

- 1

% 62.31

. % 2.98

% 34.70

% 40.83  
%4.16

% 55

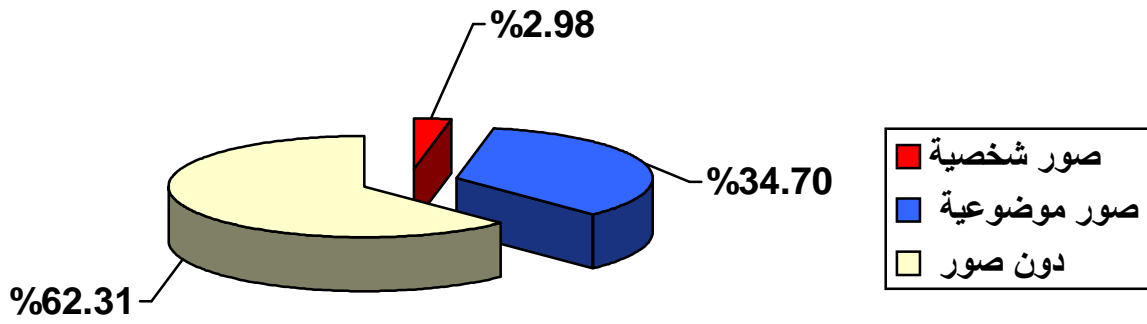

:(08)

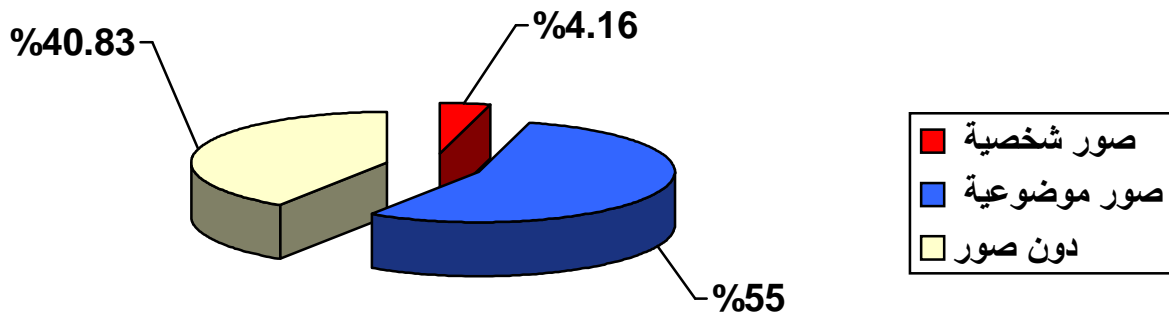

:(09)

: (08)

% 10.56	41	% 9.16	11	% 11.19	30	
% 2.06	08	% 1.66	02	% 2.23	06	
% 85.30	331	% 83.33	100	% 86.19	231	
% 2.06	08	% 5.83	07	% 0.37	01	
% 100	388	% 100	120	% 100	268	

% 10.56

% 85.30

% 2.06

:

:

- 1

% 86.19

% 2.23

% 11.19

% 0.37





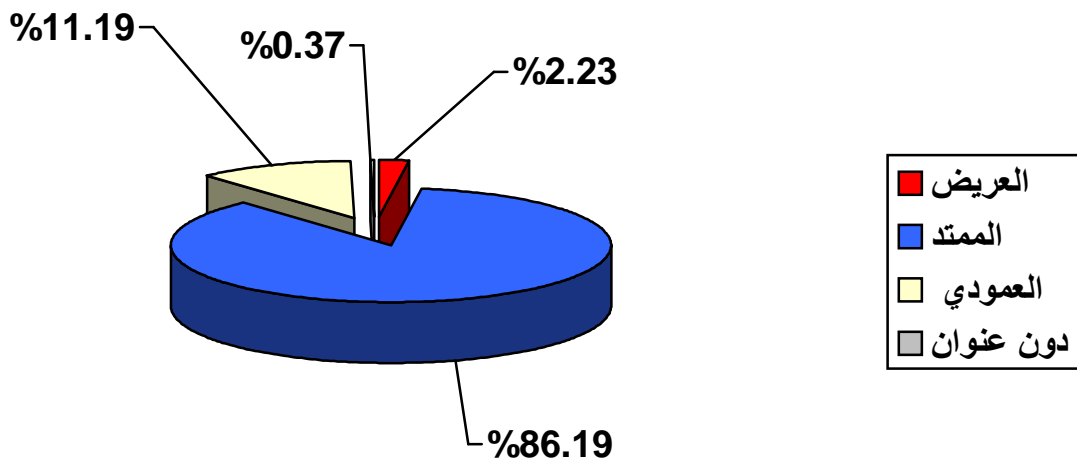

:(10)

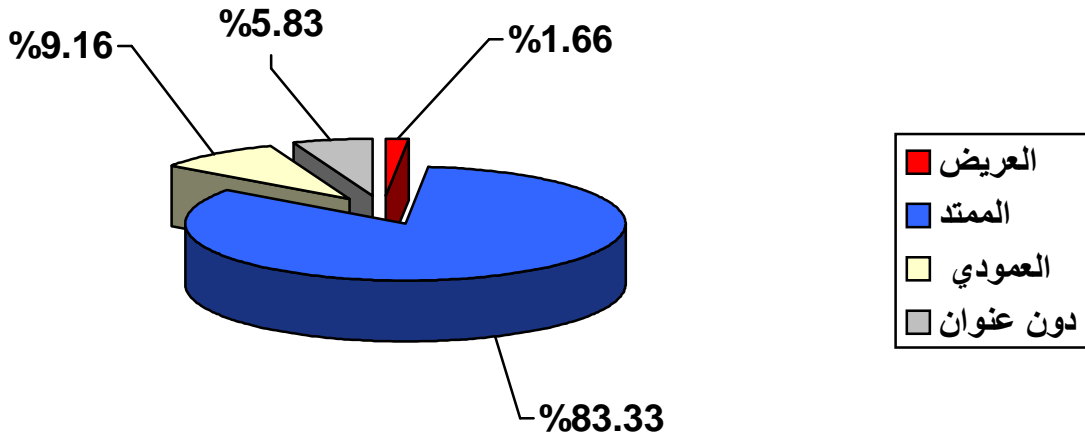

:(11)

: (09)

% 77.83	302	% 89.16	107	% 72.76	195	
% 2.06	08	% 3.33	04	% 1.49	04	
% 2.06	08	% 3.33	04	% 2.23	06	
% 17.26	67	% 3.33	04	% 23.50	63	
% 0.25	01	% 0.83	01			
% 100	388	% 100	120	% 100	268	

% 77.83

% 17.26

% 0.25

( )

:

%72.76

:

- 1

% 23.50

% 1.49

-2 :

% 89.16  
% 0.83 % 0.33

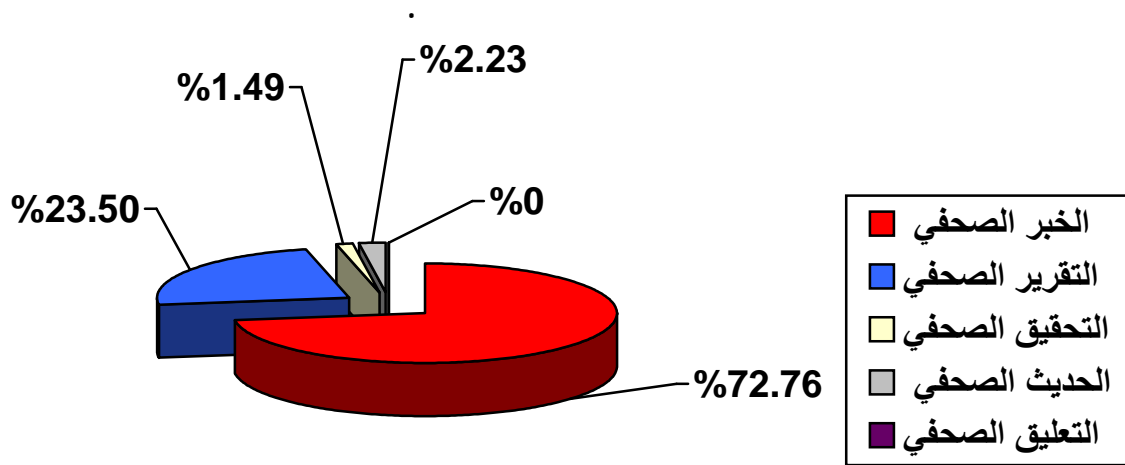

:(12)

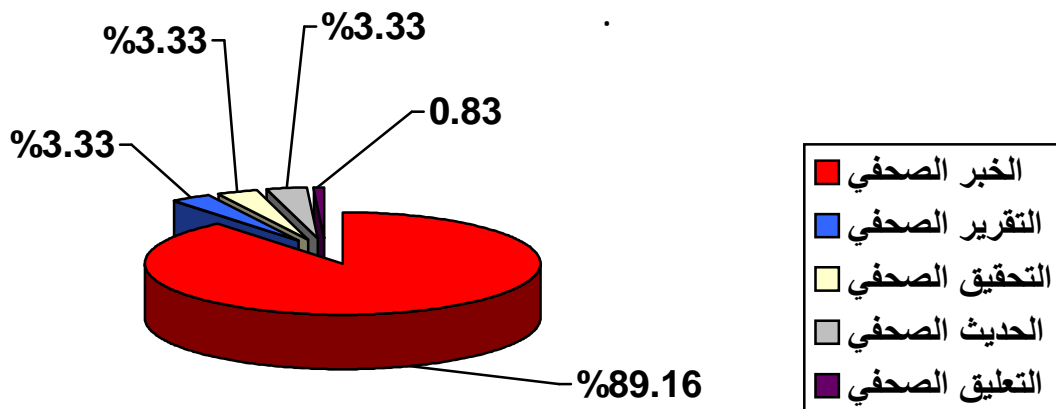

:(13)

:(10)

<b>262091.5</b>		<b>540000</b>		
<b>06.80%</b>	<b>17844.33</b>	<b>07.81%</b>	<b>42200.25</b>	

:

:

- 1

42200.25

25 :

540000

% 7.81

:

- 2

% 6.80

17844.33

262091.5

24

% 7.81

% 6.80

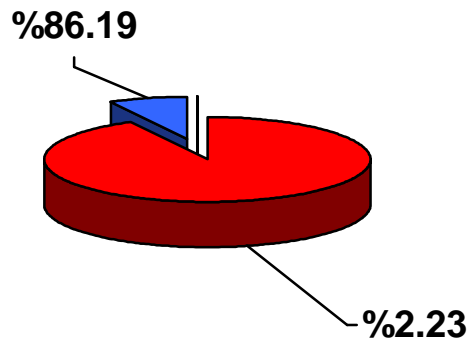

:(14)

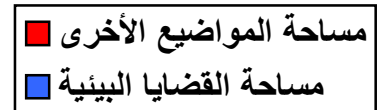
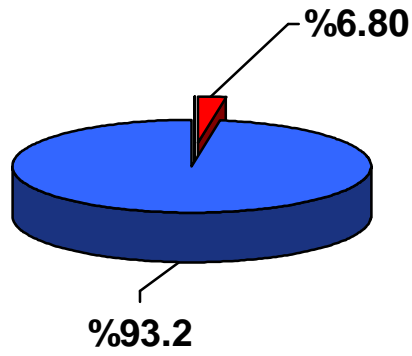

:(15)

:  
:

:(11)

<b>%1.28</b>	<b>05</b>	<b>% 0.83</b>	<b>01</b>	<b>% 1.86</b>	<b>05</b>		
<b>%2.06</b>	<b>08</b>	<b>% 0.83</b>	<b>01</b>	<b>% 2.61</b>	<b>07</b>		
<b>Ü</b>	<b>Ü</b>	<b>Ü</b>	<b>Ü</b>				
<b>Ü</b>	<b>Ü</b>	<b>Ü</b>	<b>Ü</b>				
<b>Ü</b>	<b>Ü</b>	<b>Ü</b>	<b>Ü</b>				
<b>%2.31</b>	<b>09</b>	<b>% 3.33</b>	<b>04</b>	<b>% 1.86</b>	<b>05</b>		
<b>%1.28</b>	<b>05</b>	<b>% 0.83</b>	<b>01</b>	<b>% 1.49</b>	<b>04</b>		
<b>%9.53</b>	<b>37</b>	<b>% 6.66</b>	<b>08</b>	<b>10.82</b>	<b>29</b>		
				<b>%</b>			
<b>%2.83</b>	<b>11</b>	<b>% 1.66</b>	<b>02</b>	<b>% 3.35</b>	<b>09</b>		
<b>%2.83</b>	<b>11</b>	<b>% 4.16</b>	<b>05</b>	<b>% 2.23</b>	<b>06</b>		
<b>%7.47</b>	<b>29</b>	<b>% 15</b>	<b>18</b>	<b>% 4.10</b>	<b>11</b>		
<b>%7.21</b>	<b>28</b>	<b>% 7.5</b>	<b>09</b>	<b>% 7.8</b>	<b>19</b>		
<b>%2.57</b>	<b>10</b>	<b>% 5.83</b>	<b>07</b>	<b>% 1.11</b>	<b>03</b>		
<b>19.07</b>	<b>74</b>	<b>% 37.5</b>	<b>45</b>	<b>10.82</b>	<b>29</b>		
<b>%</b>				<b>%</b>			
<b>%5.41</b>	<b>21</b>	<b>% 0.83</b>	<b>01</b>	<b>% 7.46</b>	<b>20</b>		
<b>13.91</b>	<b>54</b>	<b>% 1.66</b>	<b>02</b>	<b>19.40</b>	<b>52</b>		
<b>%</b>				<b>%</b>			
<b>%5.67</b>	<b>22</b>	<b>% 4.16</b>	<b>05</b>	<b>% 6.34</b>	<b>17</b>		
<b>%7.47</b>	<b>29</b>	<b>% 1.66</b>	<b>02</b>	<b>10.07</b>	<b>27</b>		
				<b>%</b>			
<b>%5.41</b>	<b>21</b>	<b>% 3.33</b>	<b>04</b>	<b>% 6.34</b>	<b>17</b>		
<b>%3.09</b>	<b>12</b>	<b>% 4.16</b>	<b>05</b>	<b>% 2.98</b>	<b>08</b>		
<b>%100</b>	<b>388</b>	<b>% 100</b>	<b>120</b>	<b>% 100</b>	<b>268</b>		





.

:

-2

% 37.5

% 15

%7.5

% 5.83

% 6.66

% 4.16

% 4.16

:

.

.

.



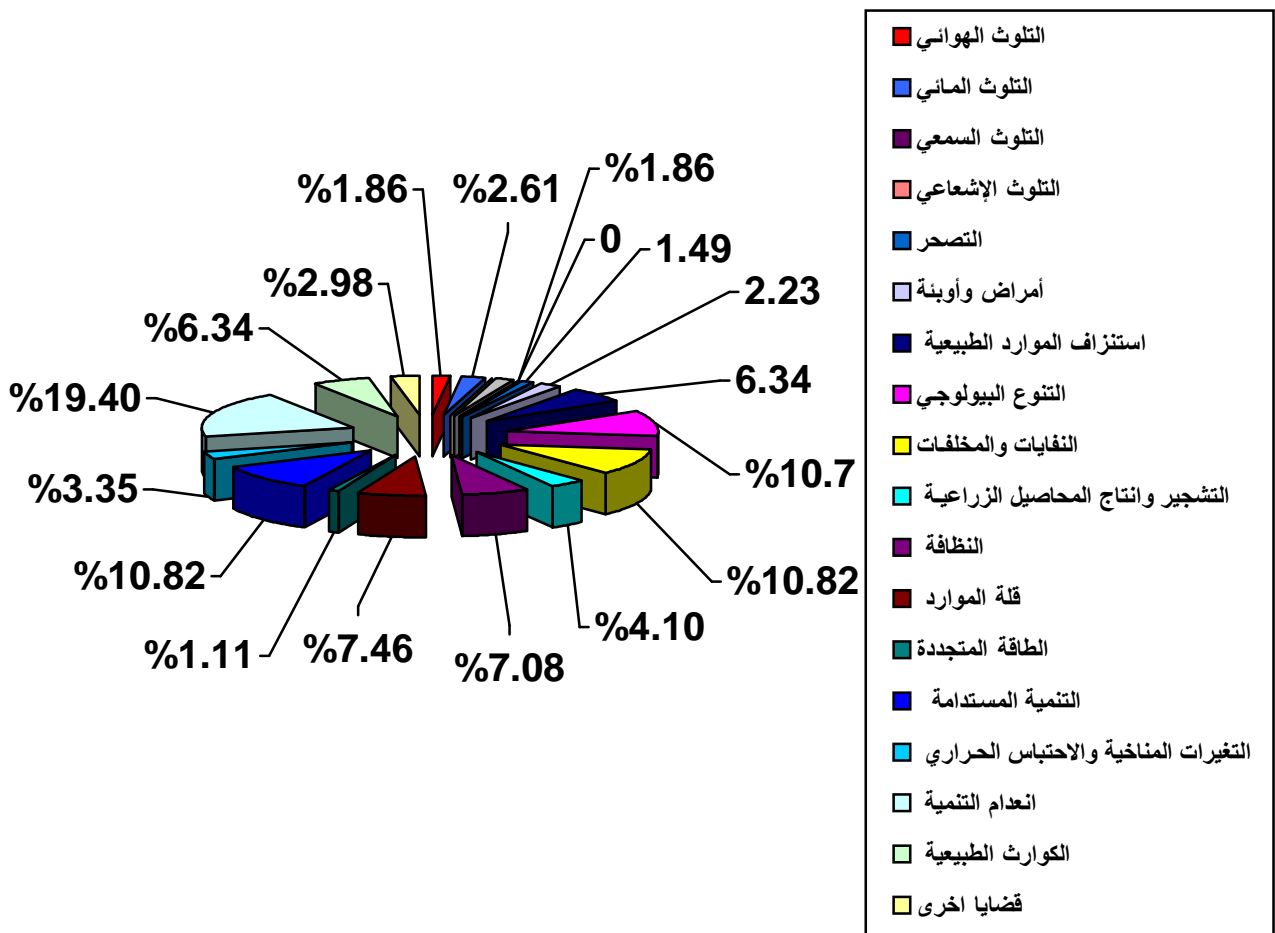

:(16)

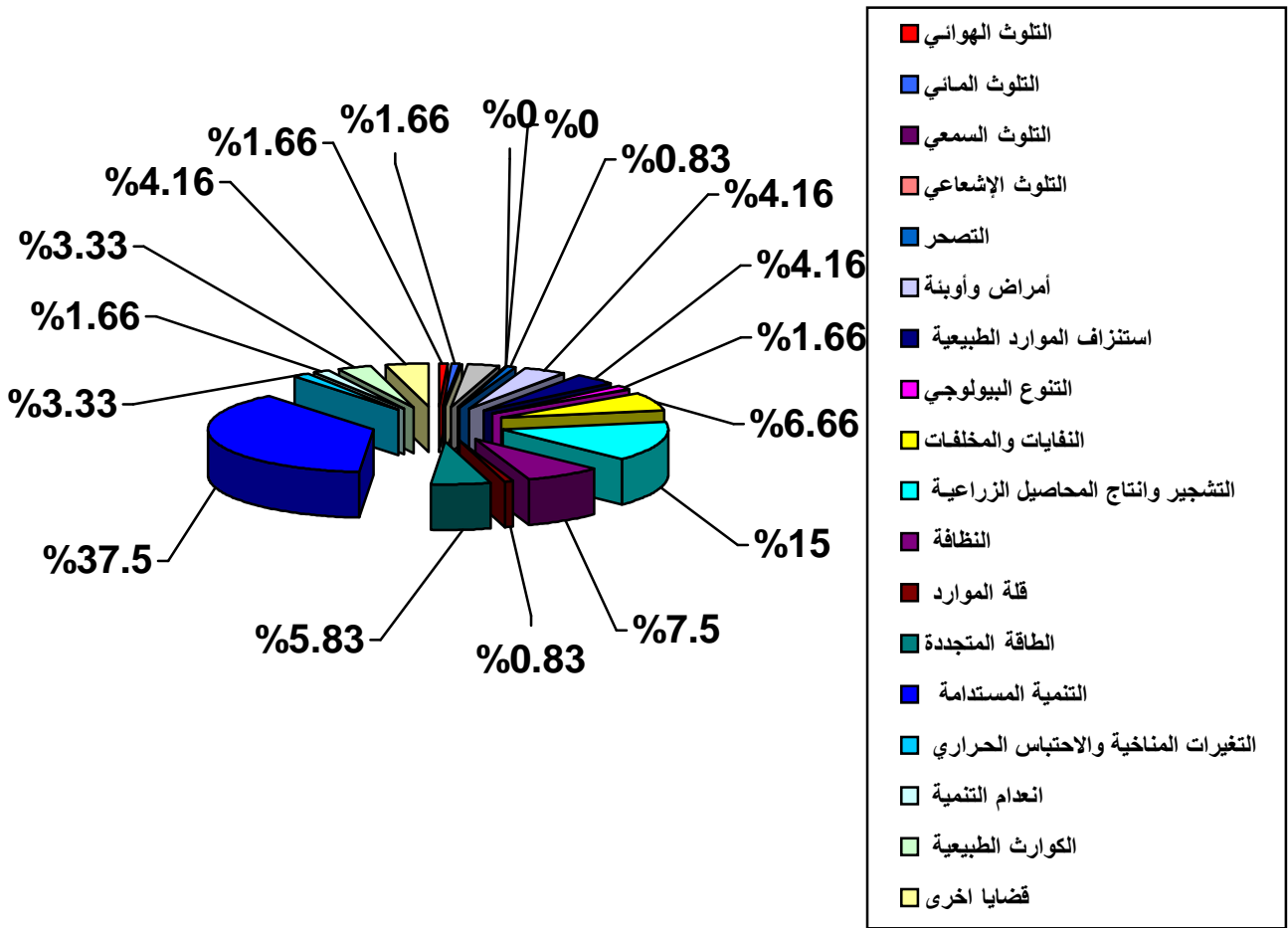

:(17)

---

:(12)

:

<b>% 8.69</b>	<b>32</b>	<b>Ü</b>	<b>Ü</b>	<b>% 11.94</b>	<b>32</b>	
<b>% 0.54</b>	<b>02</b>	<b>Ü</b>	<b>Ü</b>	<b>% 0.75</b>	<b>02</b>	
<b>%96.19</b>	<b>222</b>	<b>% 100</b>	<b>120</b>	<b>% 87.31</b>	<b>234</b>	
<b>%100</b>	<b>388</b>	<b>% 100</b>	<b>120</b>	<b>% 100</b>	<b>268</b>	

% 96.19

.% 0.54

% 8.69

:

:

- 1

% 87.31

. % 0.75

% 11.94

:

- 2

% 100

% 96.19

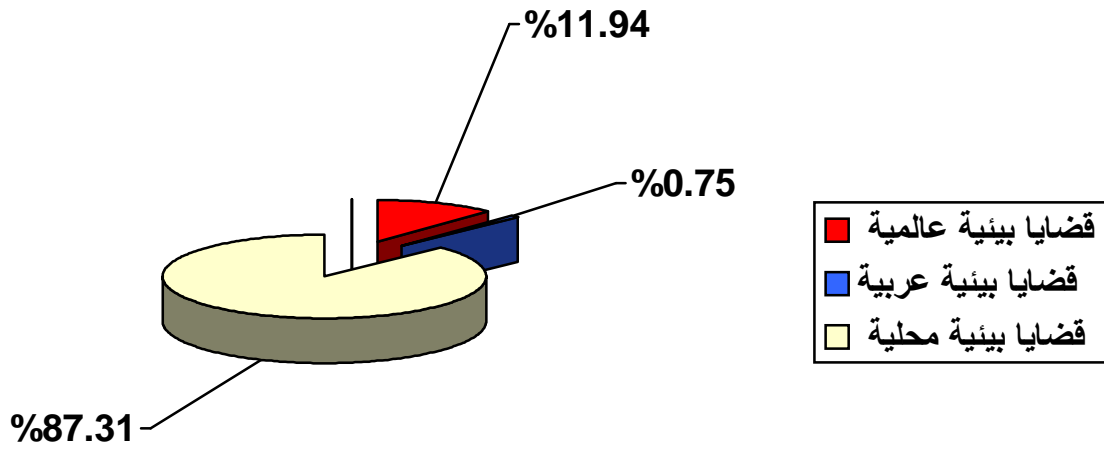

:(18)

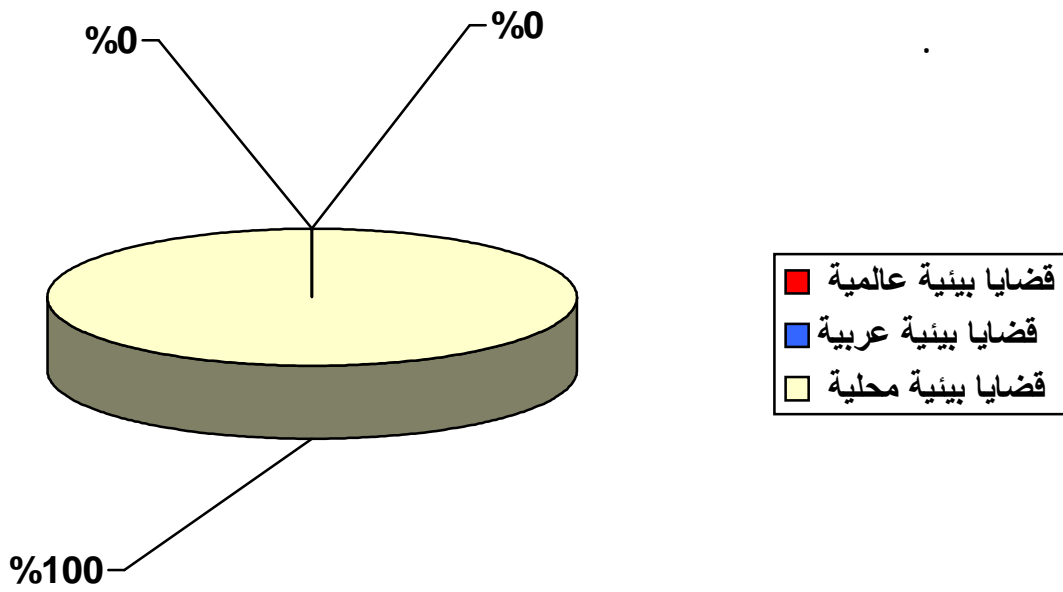

:(19)

:(13)

:

<b>% 63.14</b>	<b>245</b>	<b>% 70.83</b>	<b>85</b>	<b>% 59.70</b>	<b>160</b>	
<b>% 16.49</b>	<b>64</b>	<b>% 15.83</b>	<b>19</b>	<b>% 16.79</b>	<b>45</b>	
<b>% 20.36</b>	<b>79</b>	<b>% 13.33</b>	<b>16</b>	<b>% 23.5</b>	<b>63</b>	
<b>% 100</b>	<b>388</b>	<b>% 100</b>	<b>120</b>	<b>% 100</b>	<b>268</b>	

:

% 63.14

% 16.49

% 20.36

:

:

- 1

% 59.70

% 23.5

. % 16.79

:

- 2

% 70.83

% 15.83

. %13.33

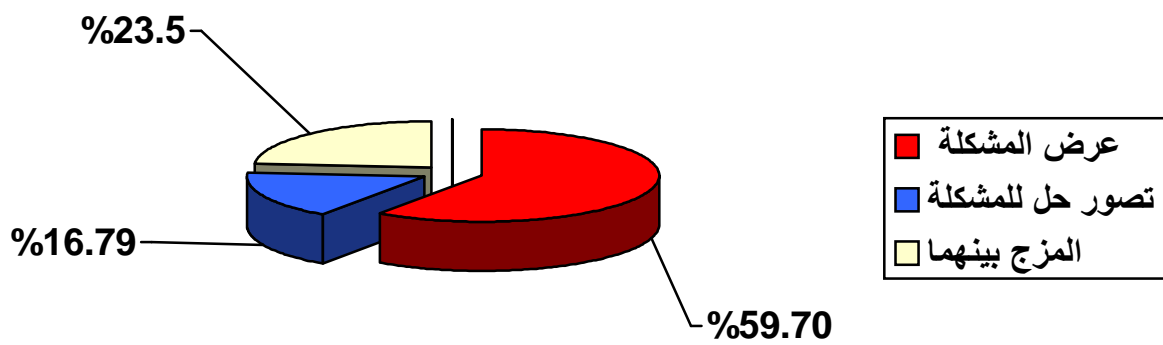

:(20)

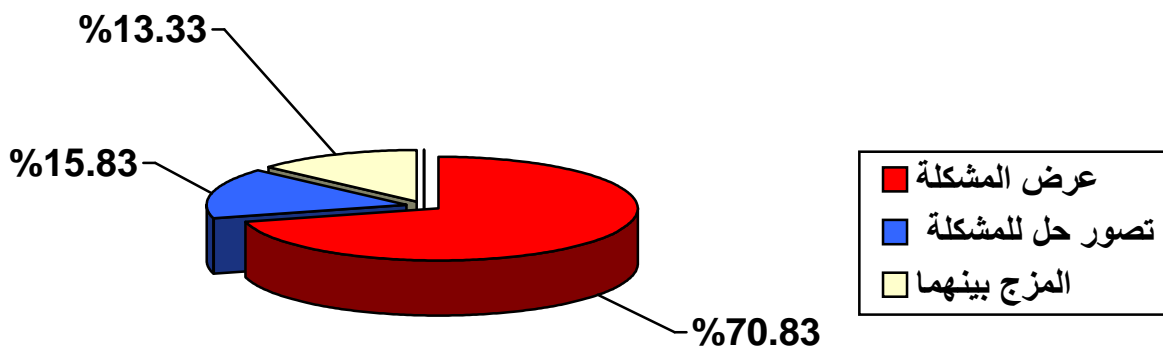

:(21)

---

:(14)

<b>% 66.23</b>	<b>257</b>	<b>% 67.5</b>	<b>81</b>	<b>% 65.67</b>	<b>176</b>	
<b>% 6.35</b>	<b>27</b>	<b>% 16.66</b>	<b>20</b>	<b>% 2.61</b>	<b>07</b>	
<b>% 26.80</b>	<b>104</b>	<b>% 15.83</b>	<b>19</b>	<b>% 31.71</b>	<b>85</b>	
<b>% 100</b>	<b>388</b>	<b>% 100</b>	<b>120</b>	<b>% 100</b>	<b>268</b>	

% 66.23

(% 06,35 ;% 26.28)

:

: -1

% 31.71

% 65.67

. % 2.61

-2 :

% 67.5

% 16.66

. % 15.83

%31.71

%2.61

%65.67

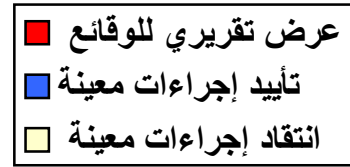

:(22)

%16.66

%15.83

%67.5

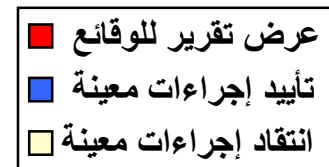

:(23)



:(15)

<b>%36.85</b>	<b>143</b>	<b>% 29.16</b>	<b>35</b>	<b>% 40.29</b>	<b>108</b>	
<b>%38.40</b>	<b>149</b>	<b>% 9.16</b>	<b>11</b>	<b>% 51.49</b>	<b>138</b>	
<b>%1.80</b>	<b>07</b>	<b>% 2.5</b>	<b>03</b>	<b>% 1.49</b>	<b>04</b>	
<b>%1.80</b>	<b>07</b>	<b>% 0.83</b>	<b>01</b>	<b>% 2.23</b>	<b>06</b>	
<b>%12.62</b>	<b>49</b>	<b>% 36.66</b>	<b>44</b>	<b>% 1.86</b>	<b>05</b>	
<b>%8.50</b>	<b>33</b>	<b>% 21.66</b>	<b>26</b>	<b>% 2.61</b>	<b>07</b>	
<b>% 100</b>	<b>388</b>	<b>% 100</b>	<b>120</b>	<b>% 100</b>	<b>268</b>	

i% 36.85

% 38.40

% 12.62

%01.80

% 08,50

:

:

- 1

% 51.49

% 40.29

% 2.61

% 1.86

% 2.23

. % 1.49



.

: -2

% 36.66

% 29.16

9.16

% 21.66

% 2.5

%

.

% 0.83

.

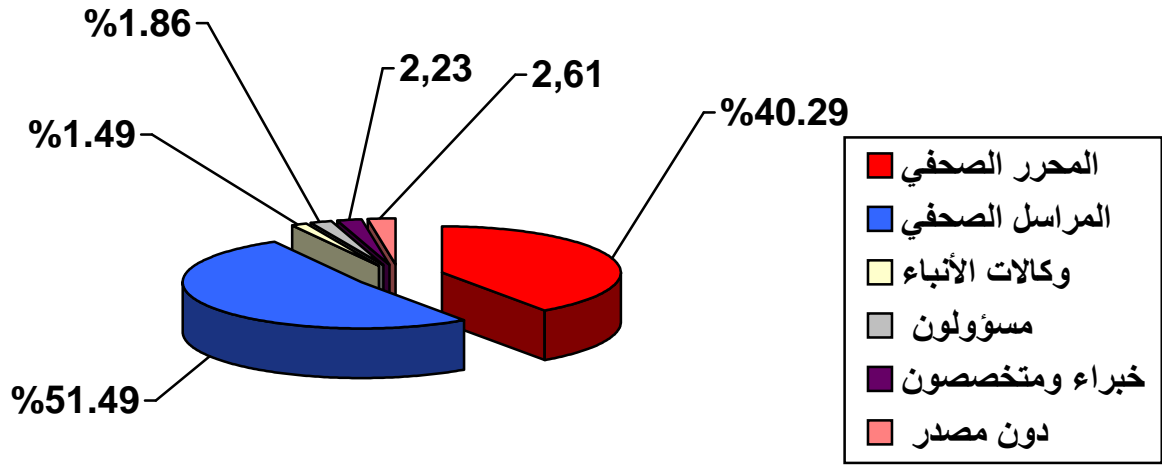

:(24)

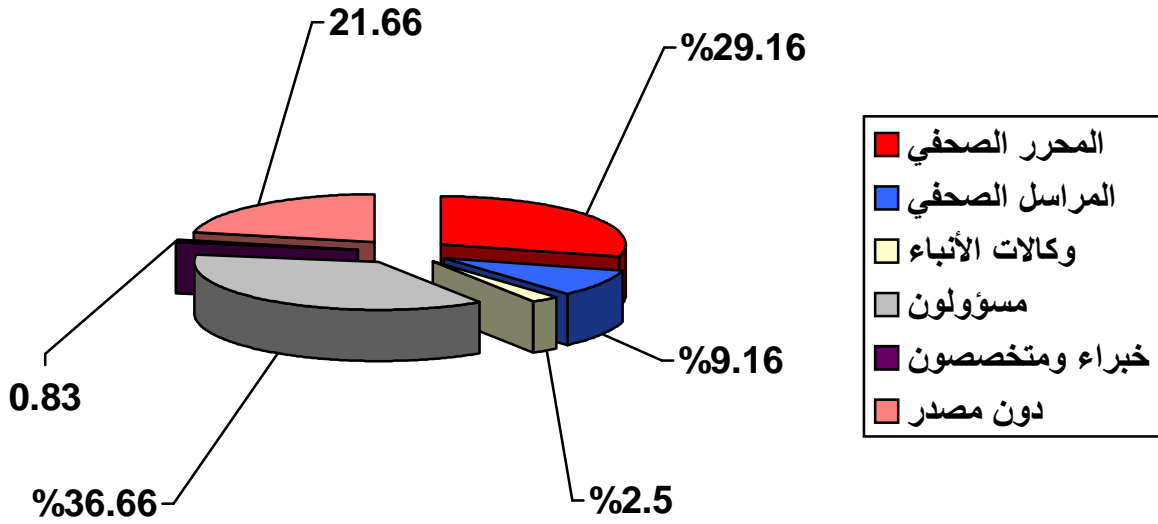

:(25)

---

:(17)

<b>% 28.60</b>	<b>111</b>	<b>% 40.33</b>	<b>49</b>	<b>% 23.13</b>	<b>62</b>	
<b>%58.76</b>	<b>228</b>	<b>% 52.5</b>	<b>63</b>	<b>% 61.56</b>	<b>165</b>	
<b>% 12.62</b>	<b>49</b>	<b>% 6.66</b>	<b>08</b>	<b>% 15.29</b>	<b>41</b>	
<b>% 100</b>	<b>388</b>	<b>% 100</b>	<b>120</b>	<b>% 100</b>	<b>268</b>	

% 58.76

. % 12.62

% 28.60

:

: - 1

% 61.56

% 23.13

. % 15.29

: - 2

% 52.5

% 40.33

. % 6.66

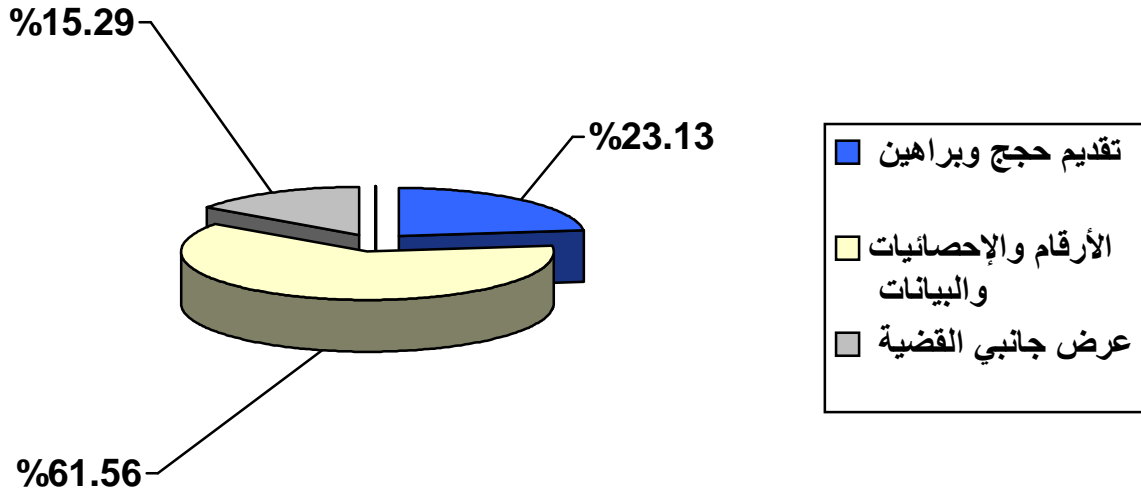

:(26)

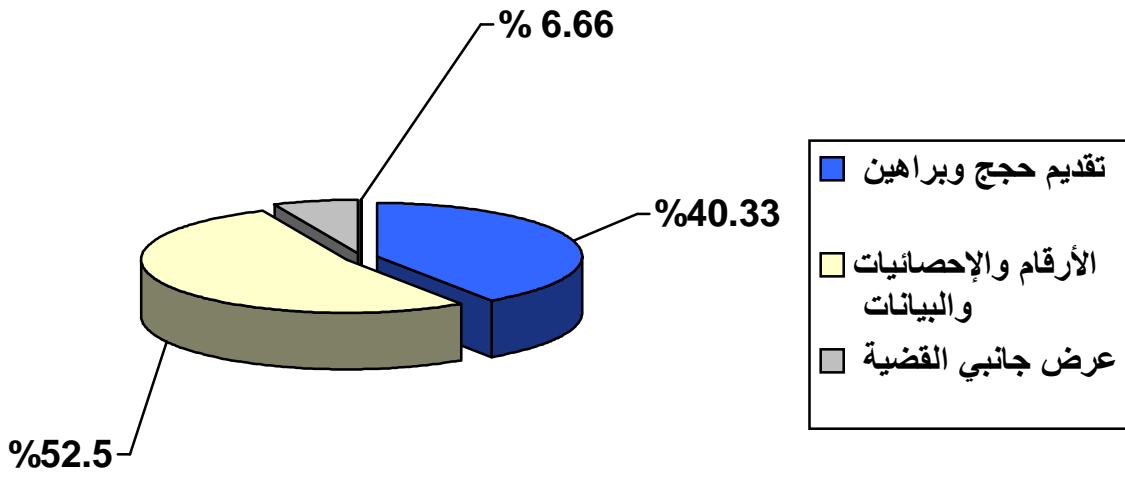

:(27)

:(18)

<b>%56.95</b>	<b>221</b>	<b>%61.66</b>	<b>74</b>	<b>% 54.85</b>	<b>147</b>	
<b>%24.48</b>	<b>101</b>	<b>% 30</b>	<b>36</b>	<b>%24.25</b>	<b>65</b>	
<b>% 14.69</b>	<b>57</b>	<b>%5.83</b>	<b>07</b>	<b>%18.65</b>	<b>50</b>	
<b>%4.63</b>	<b>09</b>	<b>%2.5</b>	<b>03</b>	<b>%2.23</b>	<b>06</b>	
<b>% 100</b>	<b>388</b>	<b>% 100</b>	<b>120</b>	<b>% 100</b>	<b>268</b>	

% 24.48

% 56.95

%4.63

% 14.69

.

:

- 1

% 54.85

% 24.25

. % 2.23

- 2

i% 30

% 61.66

%5.83

. % 2.5

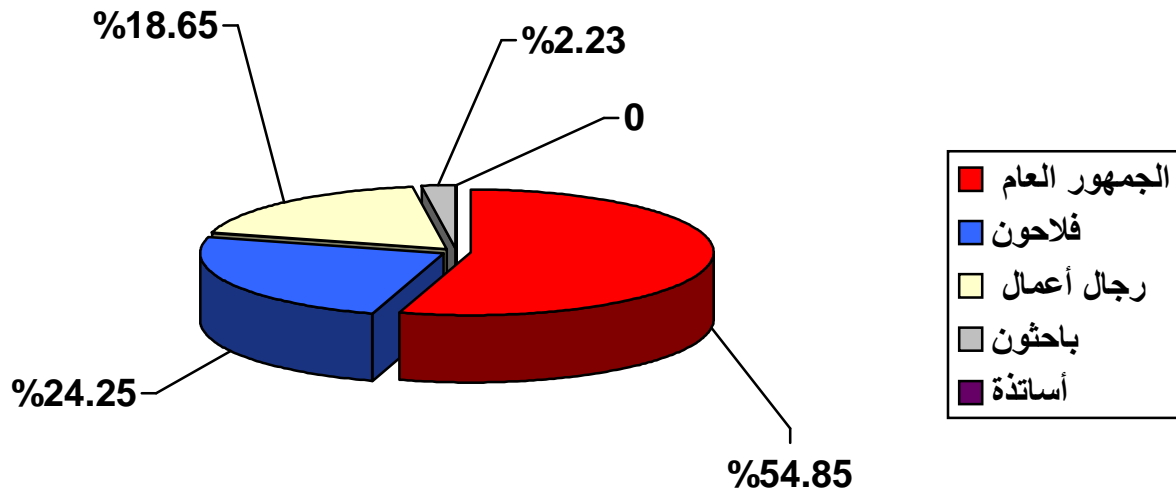

:(28)

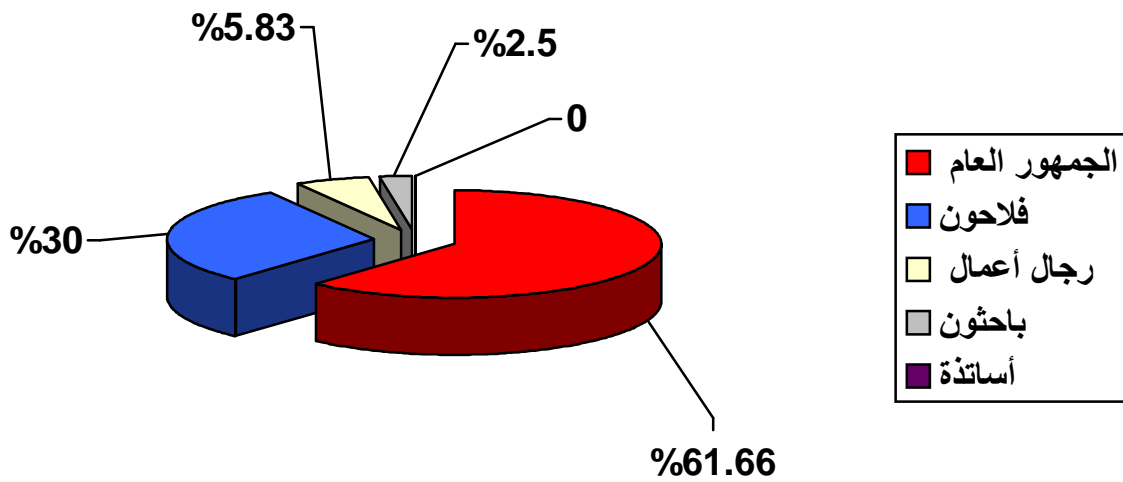

:(29)

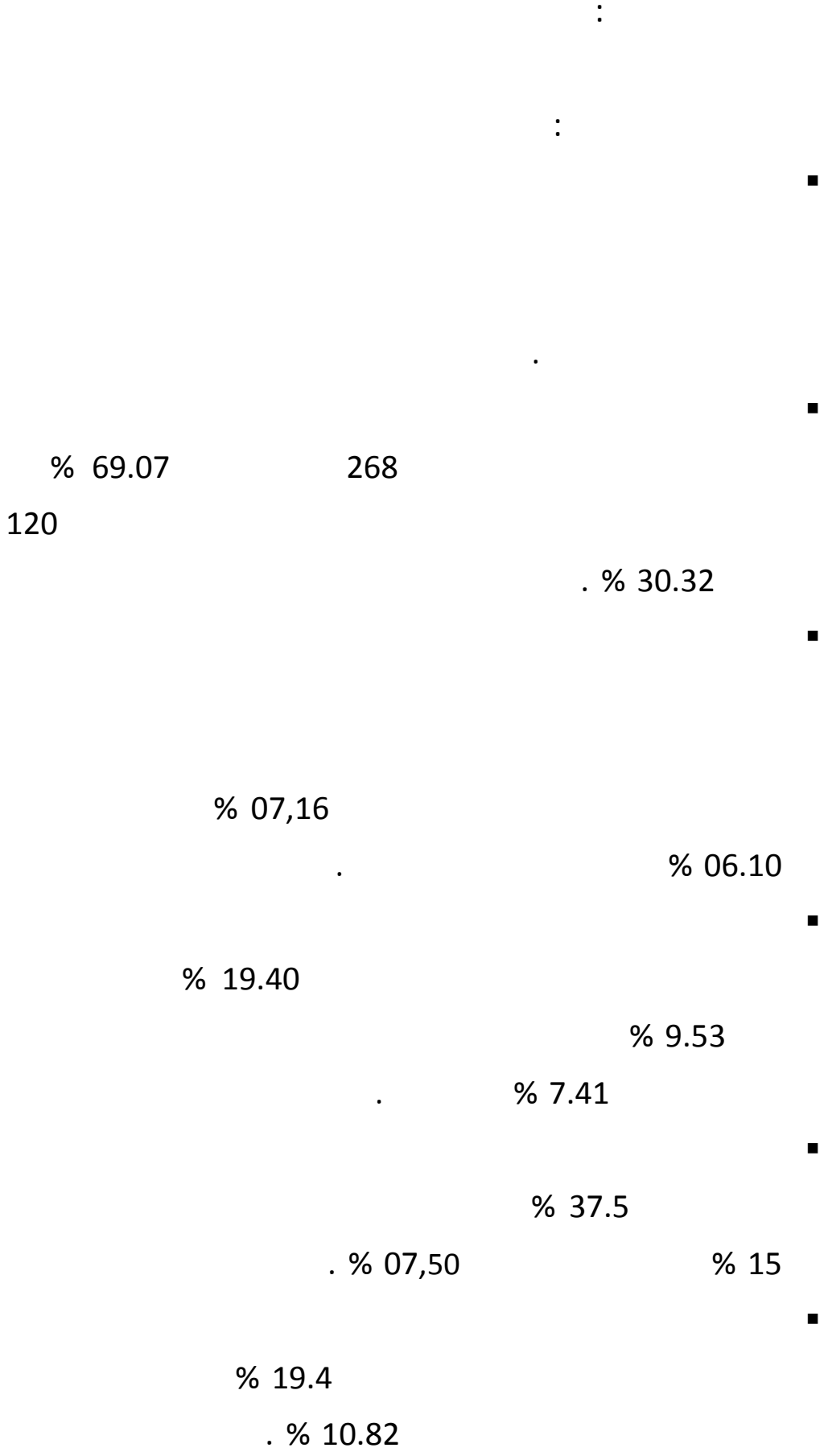





■

.

■

.

■

% 100

. 87,31

■

.

■

. % 0.75

■

. % 11.9

■

. % 66.23

■

% 34.02

% 35.82

. % 44.16

■

.



■

%58.76

. %12,62

■

%24.48

% 56.95

. % 14,69

---

:

.

.

.

.

( )

.

---

.2011

06

.

.



:

:

■

.

■

.

■

.

■

.

■

.

---

■

.

■

.

■

.

■

.

■

.

■

.

■

.

■

(

)

■

.

■

.

# قائمة المراجع

		<u>;</u>	<u>-I</u>
. 2006		:	<b>.01</b>
	. 1990	:	<b>.02</b>
		:	<b>.03</b>
		. 2002	
		:	<b>.04</b>
		. 2006	
.1999		:	<b>.05</b>
			<b>.07</b>
		. 2005	
. 2003		:	<b>.08</b>
.2009		:	<b>.09</b>
		:	<b>.10</b>
			. 1999
		:	<b>.11</b>
			. 1995
. 1992		:	<b>.12</b>
		:	<b>.13</b>
	. 1991		
. 1999		:	<b>.14</b>
		:	<b>.15</b>
		. 1999	
		:	<b>.16</b>
		. 2008	
.2009		:	<b>.17</b>



	:		<b>.18</b>
		. 2007	
	:		<b>.19</b>
		. 2008	
			<b>.20</b>
			<b>.192</b>
	:		<b>.21</b>
		. 2009	
	:		<b>.22</b>
			<b>. 2007</b>
	:		<b>.23</b>
		. 2002	
	:		<b>.24</b>
			<b>. 1985</b>
	:		<b>.25</b>
		. 1999	
. 1999			<b>.26</b>
	:		<b>.27</b>
			<b>. 2004</b>
	:		<b>.28</b>
			<b>. 2004</b>
	:		<b>.29</b>
			<b>. 1996</b>
. 1998	:		<b>.30</b>
			<b>.31</b>
	:		
		. 2002	

		:	<b>.32</b>
	. 2007		
. 2009	:		<b>.33</b>
	:		<b>.34</b>
		. 2006	
. 2001		:	<b>.35</b>
		:	<b>.36</b>
			. 1999
		:	<b>.37</b>
			. 2003
. 2007		:	<b>.38</b>
. 2001		:	<b>.39</b>
. 2009	:	:	<b>.40</b>
		:	<b>.41</b>
	. 2007		
	:		<b>.42</b>
	.		
. 1983		:	<b>.43</b>
.1991		:	<b>.44</b>
	. 2006	:	<b>.45</b>
		:	<b>.46</b>
		. 1987	
		:	<b>.47</b>
			. 2008
	:		<b>.48</b>
	. 1997		

	:	<b>.49</b>
	.1990	
. 1992	:	<b>.50</b>
. 2007	:	<b>.51</b>
	:	<b>.52</b>
	. 2003	
. 2008	:	<b>.53</b>
	:	<b>.54</b>
	. 2001	
. 2008	:	<b>.55</b>
	:	<b>.56</b>
	. 2003	
	:	<b>.57</b>
	. 1999	
	:	<b>.58</b>
	. 2008	
. 1989	:	<b>.59</b>
		<b>.60</b>
	. 2007	
	:	<b>.61</b>
. 1991		
	:	<b>.62</b>
	. 1999	
	:	<b>.63</b>
	. 2007	
	:	<b>.64</b>
	. 1999	

	:	<b>.65</b>
	. 2000	
. 2008	:	<b>.66</b>
	:	<b>.67</b>
	. 2009	
. 1998	:	<b>.68</b>
. 2002		<b>.69</b>
. 1999	:	<b>.70</b>
	:	<b>.71</b>
	. 1997	
	:	<b>.72</b>
	. 2009	
	:	<b>.73</b>
	. 1992	
.	:	<b>.74</b>
	. . .	
. 1992	:	<b>.75</b>
	:	<b>.76</b>
	. 1985	
. 2005		<b>.77</b>
	:	<b>.78</b>
	. 2003	
	:	<b>.79</b>
	. 2003	
. 1996	:	<b>.80</b>
	:	<b>.81</b>
	.	

	:	<b>.82</b>
	. 2006	
. 1988	:	<b>.83</b>
	:	<b>.84</b>
	. 2009	
	:	<b>.85</b>
	. 2010	
. 2005	:	<b>.86</b>
. 2006	:	<b>.87</b>
	:	<b>.88</b>
	. 2000	
	:	<b>-89</b>
	. 1987	
	:	<b>-</b>
	:	<b>.90</b>
	. 1992	110
	:	<b>.91</b>
	. 1998	- 154
	:	<b>.92</b>
	. 1998	154
	:	<b>.93</b>
	. 2003	19
	:	<b>.94</b>
	. 2010 i 01	
	:	<b>.95</b>
	. 1992 i12	

	:	<b>.96</b>
. 1989	03	
	:	<b>.97</b>
	. 2003	j419
	:	<b>.98</b>
	. 1992	110
	:	<b>.99</b>
<hr/>		
27		
	. 2007	
	:	<b>.100</b>
. 2004	06	
	:	<b>-</b>
	:	<b>.101</b>
. 1999		
	:	<b>.102</b>
. 2007		
	:	<b>.103</b>
. 2003		
	:	<b>.104</b>
. 1989		
	:	<b>.105</b>
. 2007		
	:	<b>.106</b>
	. 2006	
	:	<b>.107</b>
. 2000		

	:	<b>.108</b>
	. 1993	
	:	<b>.109</b>
	. 1999	
	:	<b>.110</b>
	. 2006	
	:	<b>.111</b>
	. 2007	
	:	<u>-</u>
. 1968	1 :	<b>.112</b>
.	:	<b>.113</b>
. 1980	:	<b>.114</b>
. 1979	:	<b>.115</b>
	:	<u>-</u>
10/03	i :	<b>.116</b>
. 43		2003/07/20
	:	<b>.117</b>
		. 2001
	:	<u>-</u>
	:	<b>.118</b>
11 7		
		. 1985

: .119

. 2008 08 07

: .120

. 2009

: .121

. 2008 08 07

: .123

.2005/07/06

: .124

. 1992

: .125

. 1992

: .126

. 1992

: .127

. 2008 08 07

: .128

. 1989

: .129



. 2008 08 07

:\_\_\_\_\_ -II

أ- الكتب باللغة الفرنسية:

130 .prieur Michel :droit de le Environnement , 4 ed dolloz , 2001.

:\_\_\_\_\_ -

131. le petit rober , 1ed, pares, 1991 .

:\_\_\_\_\_ -

132. Mission Economique de l’Ambassade de France en Algérie:

Fiche de synthèse sur le marché de l’environnement en Algérie,

MINEFI-DGPTE, version n° 1 , du 14 mars 2004.

133.Ministér de L’aménagement du Territoire et de l’environnement

Rapport sur l’état et l’avenir de l’environnement, Alger , 2005 .

:\_\_\_\_\_ -III

:\_\_\_\_\_ -

134.John Rau and David Wooter :Environmental impact analysis

Hand Book- univ of California , Meg Raw – Hill company 1980.

135. J. Seneca M.K. Jaussig : Environmental Economics , New jersey,  
Prentice-Hall, 1984 .

:\_\_\_\_\_ -

136. Langman distiouary of contumpary English :éd 1984.

\_\_\_\_\_ - IV

137. WWW.wakteldjazair.com

الملاحق





<b>05</b>	
06	.....
08	.....
08	.....
09	.....
10	.....
10	.....
12	.....
23	.....
24	.....
28	.....
36	.....
37	.....
<b>38</b>	..... :
39	.....
40	..... :
40	..... :
43	..... :
44	..... :
45	..... :
46	..... :
47	..... :
48	..... :
46	..... :
47	..... :
50	..... :

50	.....	:
51	.....	:
52	.....	:
53	.....	:
56	.....	:
58	.....	:
61	.....	:
62	.....	:
74	.....	:
75	.....	:
77	.....	:
79	.....	:
82	.....	:
84	.....	:
88	.....	:
<b>89</b>		:
90	.....	:
91	.....	:
93	.....	:
93	.....	:
94	.....	:
97	.....	:
98	.....	:
99	.....	:
100	.....	:
101	.....	:
102	.....	:
104	.....	:
105	.....	:

107	.....	:
109	.....	:
109	.....	:
110	.....	:
111	.....	:
111	.....	:
112	.....	:
113	.....	:
114	.....	:
115	.....	:
116	.....	:
117	.....	:
118	.....	:
119	.....	:
122	.....	:

<b>123</b>		:
------------	--	---

124	.....	
125	.....	
142	.....	
160	.....	
163	.....	
165	.....	
	.....	
	.....	

---

:\_\_\_\_\_

26	:(1)
27	:(2)
126	:(3)
127	:(4)
129	:(5)
131	:(6)
133	:(7)
135	:(9)
138	:(10)
140	:(11)
142	:(12)
147	:(13)
149	:(14)
151	:(15)
153	:(16)
152	:(17)
158	:(18)



---

---

126	:(01)
128	:(02)
128	:(03)
130	:(04)
130	:(05)
132	:(06)
134	:(07)
134	:(08)
130	:(09)
136	:(10)
136	:(11)

---

139	:(12)
139	:(13)
141	:(14)
141	:(15)
145	:(16)
146	:(17)
148	:(18)
150	:(19)
150	:(20)
146	:(21)
152	:(22)
152	:(23)
155	:(24)

155	:(25)
157	:(26)
157	:(27)
159	:(28)
159	:(29)

عَنْ جَسْرٍ إِلَى اللَّهِ